

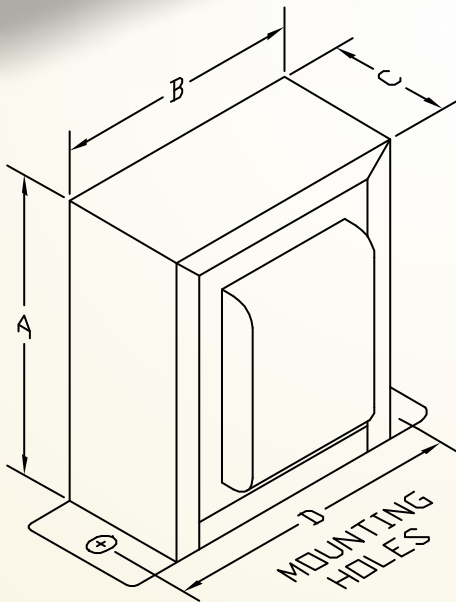

70 volt/100 volt 100 WATT AUTOFORMER for use in distributed systems

PART # THSPM100

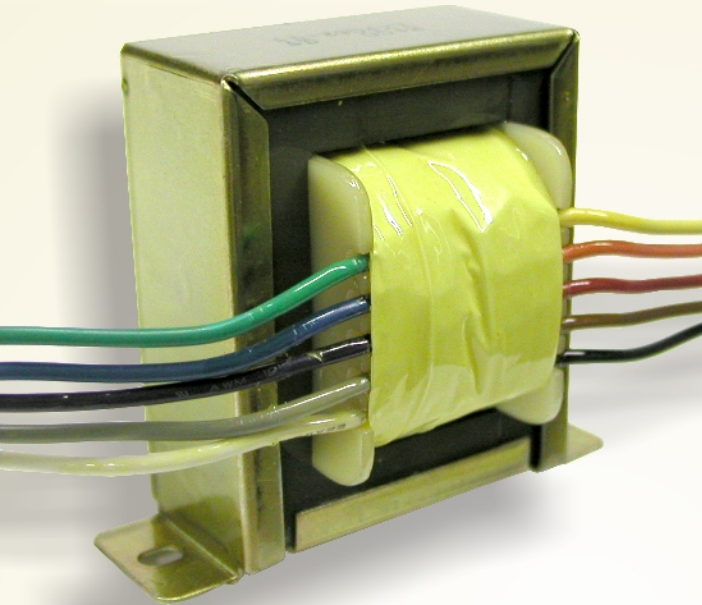

WATTS @100V	WATTS @ 70V	IMPEDANCE	
		COMMON	BLK
		8 OHMS	BRN
		16 OHMS	RED
	100W	50 OHMS	ORN
100W	50W	100 OHMS	YEL
50W	25W	200 OHMS	GRN
25W	12.5W	400 OHMS	BLU
12.5W	6.25W	800 OHMS	VIO
6.25W	3.125W	1600 OHMS	GRY
3.125W	1.56W	3200 OHMS	WHT

Model No.	Power Rating	Freq. Response	Terminations
THSPM100	100 Watts	35Hz-19KHz +/-1dB	22 AWG Wires

DIMENSIONS					
A	B	C	D	HOLE DIA.	WEIGHT
2.80" (71.12mm)	2.31" (58.67mm)	1.15" (29.21mm)	2.78" (70.61mm)	0.18" (4.57mm)	1.7 lbs (0.77kg)

THSPM100



*Specifications subject to change without notice.

601 E. Pawnee Wichita, KS 67211 316.263.2852 FAX 316.263.0642 www.galaxyaudio.com

Distributed outside the United States by E and E Exports, Inc. 2815 Junipero Ave. Suite 101 Signal Hill, CA 92614 562.988.3447 FAX 562.989.3037
Distributed in Canada by Audio Distributors International (ADI) 1275 Newton, unit 6 Boucherville, QC J4B 5H2 Canada 450.449.8177 FAX 450.449.8180

V03092012